



NATIONAL TECHNICAL UNIVERSITY OF ATHENS

School of Civil Engineering

Institute of Structural Analysis & Antiseismic Research

Dr. Sapountzakis J. Evangelos

Dr. Civil Engineer NTUA

Professor NTUA

*Calculation of Shear Areas and Torsional Constant
using the Boundary Element Method
with Scada Pro Software*

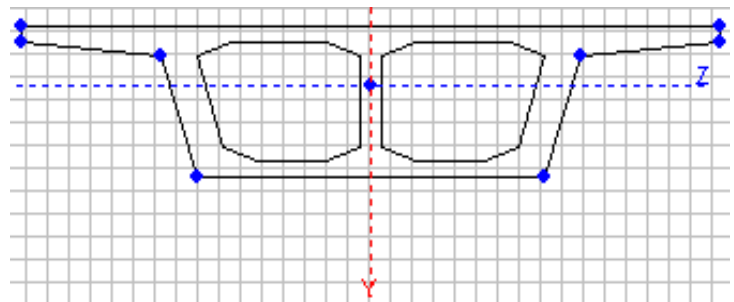
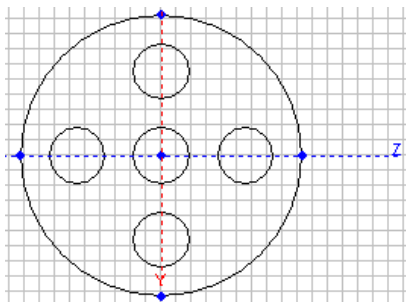
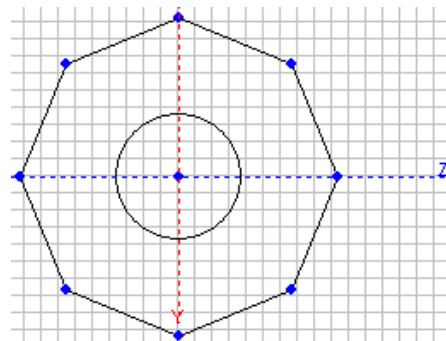
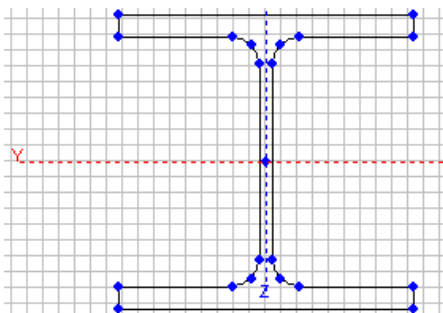

Athens 2015



Contents

1. Introduction.....	3
2. Calculation of Torsional Constant.....	4
3. Calculation of Shear Areas.....	7
4. Applications with Scada Pro.....	10
4.1 Cross-Section 1.....	10
4.2 Cross-Section 2.....	11
4.3 Cross-Section 3.....	12
4.4 Cross-Section 4.....	13

This publication constitutes a collaboration product between the Institute of Structural Analysis & Antiseismic Research (ISAAR) of National Technical University of Athens (NTUA) and ACE-Hellas S.A.

	Institute of Structural Analysis & Antiseismic Research of NTUA	ACE-Hellas A.E.
Design	Vasileios G. Mokos Civil Engineer, M.Sc., PhD	
Check	Evangelos J. Sapountzakis Dr. Civil Engineer NTUA Civil Engineer, M.Sc., DIC, PhD Professor NTUA	



1. Introduction

In a bar with arbitrary cross-section, the coordinates of the center of gravity as well as the bending moments of inertia can be calculated analytically, i.e. using closed-form relationships. However, shear areas as well as torsional constant can be calculated analytically only for bars with simple geometry cross-sections, while in all other cases the calculation is accomplished only numerically, since solution of boundary value problems are required. Boundary value problems can be solved using numerical methods such as the Finite Element Method (FEM) or the Boundary Element Method (BEM) [1.1].

In order to solve the above boundary value problems and to calculate the shear areas and torsional constant, the Boundary Element Method with Scada Pro is implemented. It is worth here noting that in the Boundary Element Method only the boundary of the cross-section (with boundary elements) is discretized (Img.1.1a), unlike the Finite Element Method in which the entire interior area of the cross-section is discretized (using surface elements) (Img.1.1b). This results in Boundary Element Method, a more simple process of discretization and significantly reduce the number of unknowns. It is also stressed that the Boundary Element Method has a rigorous mathematical approach, which means that the method is so accurate that the results can be considered to be practically precise.

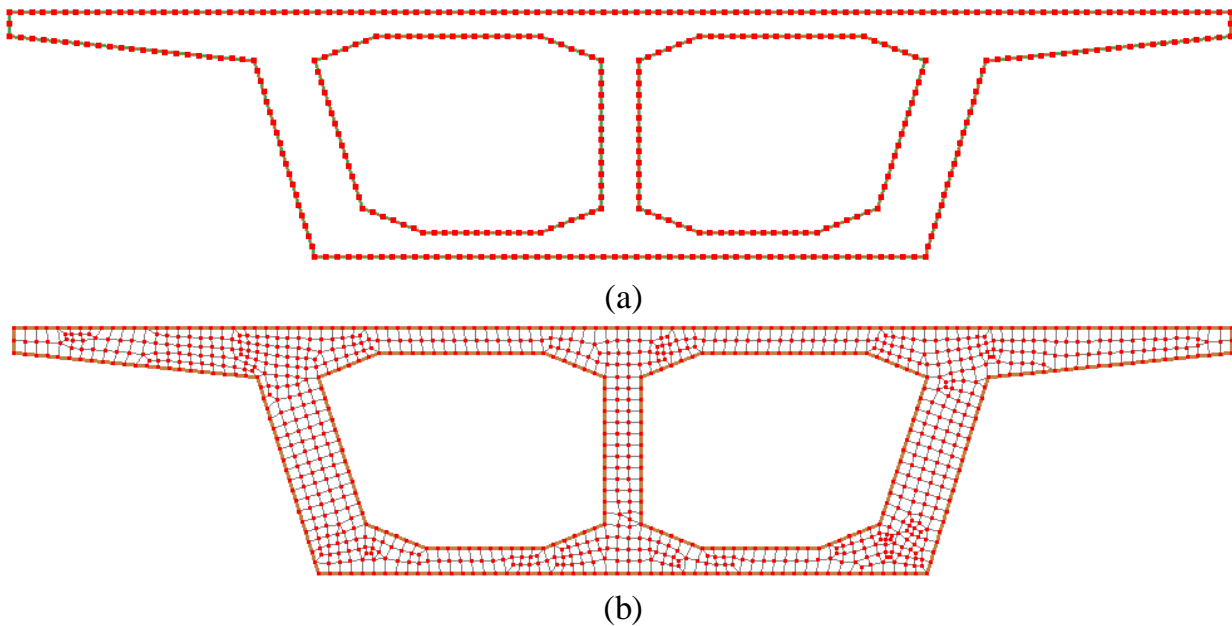

Img. 1.1. Box shaped cross-section discretization with the Boundary Element Method (a) & with the Finite Element Method (b).

BIBLIOGRAPHY

- [1.1]. Katsikadelis, J.T (2002) *Boundary Elements: Theory and Application*, Elsevier, Amsterdam-London.

2. Calculation of torsional constant

Torsion is a load in which a transverse force is applied at a distance from the reference axis of the bar, creating in this way a torque vector M_t having the reference axis of the bar direction. Torsion in bar elements is created when the plane of the external load does not pass through the shear center S of their cross-section. It is also known that the deformation of a bar with non-circular cross-section subjected to twisting moment, consists of a rotation of the cross-section about the torsional axis of the bar and a torsional warping of the cross-section (Img.2.1b).

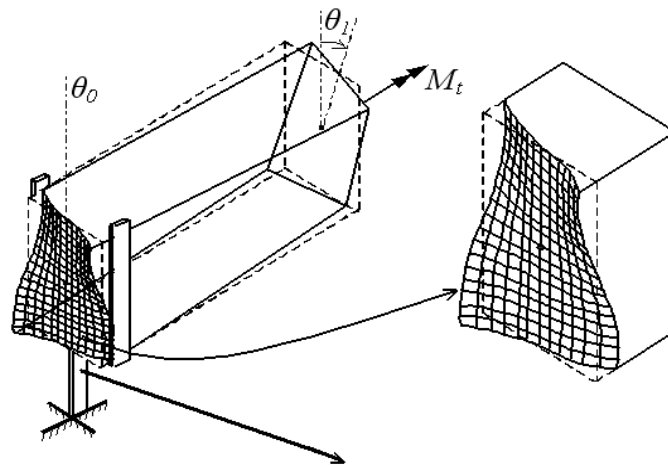

Simple torsional support (forked)

(a)

(b)

Img. 2.1. Free torsional warping of a rectangular cross-section.

When the torsional warping of the cross-section of the member is not restrained (Img.2.1a) the applied twisting moment is undertaken from the Saint-Venant shear stresses [2.1]. In this case the angle of twist per unit length remains constant along the bar and the torsion is characterized as *uniform*.

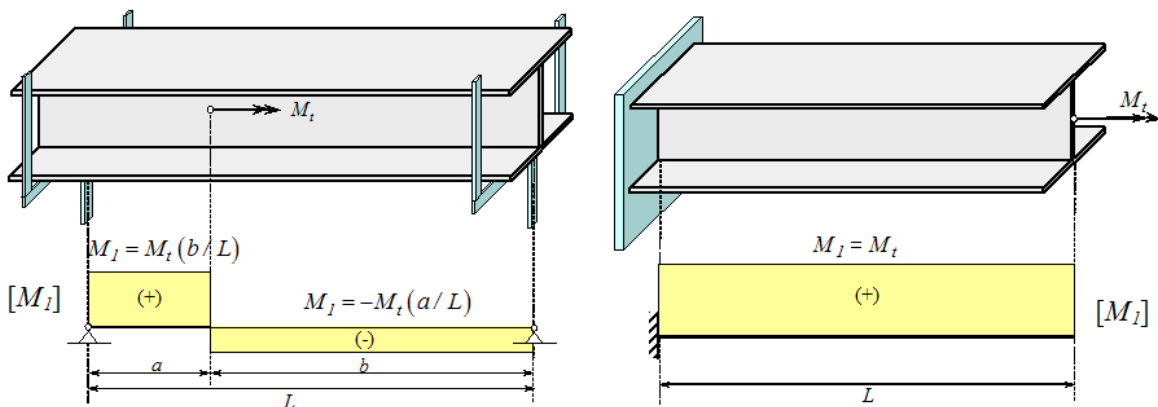

Img. 2.2. Nonuniform torsion of bars due to internal loading and boundary conditions.

On the contrary, in most cases either arbitrary torsional boundary conditions are applied at the edges or concentrated twisting body forces at any other interior point of the bar due to construction requirements. This bar under the action of general twisting loading is led to *nonuniform* torsion, while the angle of twist per unit length is no longer constant along it (Img.2.2).

The uniform torsion (*Saint Venant* torsion) is characterized by the torsional constant of the section I_t . More specifically, the above-applied constant along the axis of the element torque M_t is obtained from the equation

$$M_t = GI_t \theta'_x \quad (2.1)$$

where x stands for the axis of the member, G is the shear modulus of the material of the bar, $\theta'_x = d\theta_x / dx$ denotes the rate of change of the angle of twist θ and it can be regarded as the torsional curvature, while the variable I_t is called torsional moment of inertia according to *Saint Venant* or *torsional constant* and is calculated from the equation

$$I_t = \int_{\Omega} \left(y^2 + z^2 + y \frac{\partial \phi_S}{\partial z} - z \frac{\partial \phi_S}{\partial y} \right) d\Omega \quad (2.2)$$

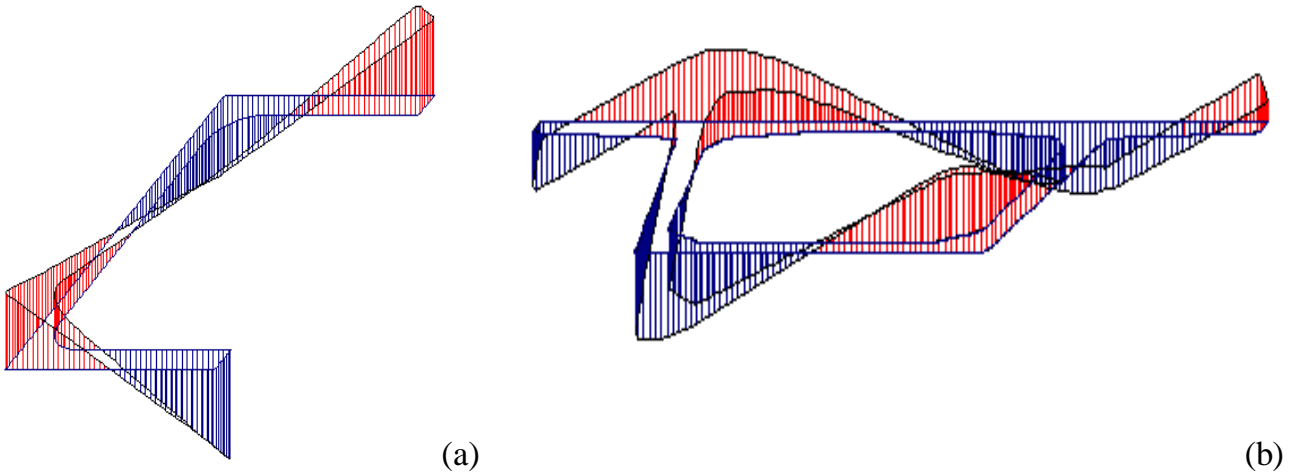

Img. 2.3. Warping function ϕ_S for (a) standard UPE-100 and (b) Box shaped bar cross-sections.

where $\phi_S(y, z)$ is the (torsional) warping function with respect to the shear center S of the bar's cross-section (Img.2.3). The warping function ϕ_S expresses the warping (longitudinal displacement) which is the result of single-unit relative angle of twist ($\theta'_x = 1$), while, as the same definition introduces, it depends only from the geometry of the section, i.e. it's its independent of the coordinate x parameter. Finally, the quantity GI_t is called *torsional rigidity* of the cross-section. In the previous, we have consider a bar with constant (along the longitudinal axis of the bar) cross-section with an arbitrarily shaped occupying the two-dimensional simply or multiply connected region Ω of the $y; z$ plane bounded by the curve Γ .



The calculation of the warping function ϕ_S is achieved by solving the following boundary value problem [2.2, 2.3]

$$\nabla^2 \phi_S = \frac{\partial^2 \phi_S}{\partial y^2} + \frac{\partial^2 \phi_S}{\partial z^2} = 0 \quad \text{in } \Omega \quad (2.3a)$$

$$\frac{\partial \phi_S}{\partial n} = zn_y - yn_z \quad \text{on } \Gamma \quad (2.3b)$$

where $n_y = \cos(y, n) = dy/dn$ and $n_z = \sin(z, n) = dz/dn$ are the directional cosines of the external normal vector n to the boundary of the cross-section. The aforementioned boundary value problem arises from the equation of equilibrium of the three-dimensional theory of elasticity neglecting the body forces and the physical consideration that the traction vector in the direction of the normal vector n vanishes on the free surface of the bar.

The numerical solution of the boundary value problem stated above (2.3a,b) for the evaluation of the warping function ϕ_S , is accomplished employing a pure BEM approach [2.4], that uses only boundary discretization. Finally, since the uniform torsion problem is solved by the BEM, the domain integral in equation (2.2) is converted to boundary line integral in order to maintain the pure boundary character of the method [2.3]. Thus, once the aforementioned warping function is established along the boundary, the torsional constant I_t is evaluated using only boundary integration.

BIBLIOGRAPHY

- [2.1]. Saint-Venant B. (1855) "Memoire sur la torsion des prismes", *Memoires des Savants Etrangers*, 14, 233-560.
- [2.2]. Sapountzakis E.J. (2000) "Solution of Nonuniform Torsion of Bars by an Integral Equation Method", *Computers and Structures*, 77, 659-667.
- [2.3]. Sapountzakis E.J. and Mokos V.G. (2004) "3-D Elastic Beam Element of Composite or Homogeneous Cross Section Including Warping Effect with Applications to Spatial Structures", *Technika Chronika, Scientific Journal of the TCG, Section I, Civil Engineering, Rural and Surveying Engineering*, 24(1-3), 115-139.
- [2.4]. Katsikadelis, J.T (2002) *Boundary Elements: Theory and Application*, Elsevier, Amsterdam-London.

3. Calculation of shear areas

Beam element subjected to transverse forces develops a shear strain, which is almost always associated with flexural strain. In case that the direction of the externally imposed transverse forces passes through the shear center of the cross-section of the beam, shear strain is developed exclusively (absence of torsion), as the shear center is the point of the cross-section of which the internally developed shear force passes through (shear stresses integral).

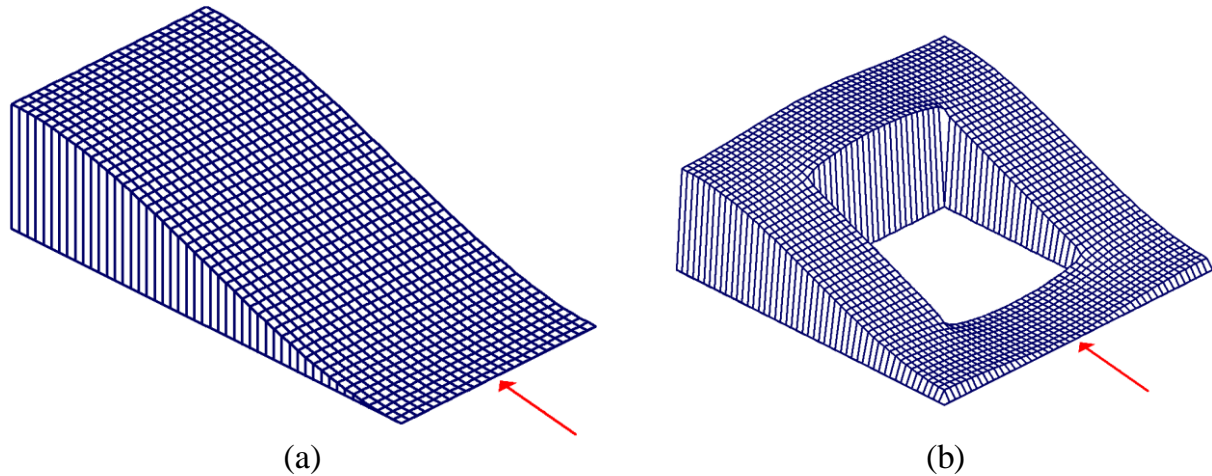

Img. 3.1. Warping due to shear force for rectangular (a) and square hollow (b) section.

In general cases, in the cross-section of the beam, shear stresses caused by shear forces are developed nonuniformly. Thus, the distribution of the shear deformation will be nonuniform, which forces the cross-section to shear warping along the longitudinal direction, i.e. Bernoulli's acceptance rule (plane cross-sections remain plane and orthogonal to the deformed beam axis after flexural) can no longer be assumed (*Euler-Bernoulli flexural beam theory*) (Img.3.1).

If the shear force is constant along the axis of the beam and the longitudinal displacements causing the warping are not restrained, the applied shear load is undertaken only by shear stresses which are maximized at the boundary of the cross-section. This type of shear is called *uniform*. Conversely, if the shear force varies along the beam and/or the shear warping is restrained by load or support conditions the shear stress is developed nonuniformly and shear is called *nonuniform*.

The warping due to shear is generally small compared to the corresponding due to torsion, thus the warping stresses due to shear can be reasonably ignored in the analysis. Thus, the stress field of the beam due to shear force is usually determined considering uniform shearing, while the displacement field including shear warping is taken into account indirectly through appropriate shear correction factors. Timoshenko (1921) was the first to take into account the influence of the shearing deformation through shear correction factors (κ), by suitably modifying the equilibrium equations of the beam. For that reason the beam theory that takes into account the influence of shear deformations is also known as *Timoshenko flexural beam theory*. Note that the inverse of the shear correction factor (κ) is



called shear deformation coefficient ($a = 1/\kappa$), while with the aid of these coefficients the shear areas of the cross-section of the beam can be easily derived, as will occur in the next.

More specifically, the shear areas of the beam cross-section loaded by constant shear force (Q_y , Q_z components, along y , z axis, respectively) are given by the equations

$$A_y = \kappa_y A = \frac{A}{\alpha_y} \quad , \quad A_z = \kappa_z A = \frac{A}{\alpha_z} \quad (3.1a,b)$$

while, the cross-section shear rigidities of the Timoshenko's flexural beam theory are identified as

$$GA_y = \kappa_y GA = \frac{GA}{\alpha_y} \quad , \quad GA_z = \kappa_z GA = \frac{GA}{\alpha_z} \quad (3.2a,b)$$

where, the shear deformation coefficients α_y , α_z are determined by the equations [3.1-3.3]

$$\alpha_y = \frac{AG^2}{Q_y^2} \int_{\Omega} \left[\left(\frac{\partial \phi_{cy}}{\partial y} \right)^2 + \left(\frac{\partial \phi_{cy}}{\partial z} \right)^2 \right] d\Omega \quad (3.3a)$$

$$\alpha_z = \frac{AG^2}{Q_z^2} \int_{\Omega} \left[\left(\frac{\partial \phi_{cz}}{\partial y} \right)^2 + \left(\frac{\partial \phi_{cz}}{\partial z} \right)^2 \right] d\Omega \quad (3.3b)$$

In equations (3.3a,b) the ϕ_{cy} , ϕ_{cz} are the (shear) warping functions resulting from solving the following boundary value problem [3.1-3.3]

$$\nabla^2 \phi_c(y, z) = \frac{\partial^2 \phi_c}{\partial y^2} + \frac{\partial^2 \phi_c}{\partial z^2} = -\frac{1}{GI_{yy}I_{zz}} (Q_z I_{zz} z + Q_y I_{zz} y) \quad \text{in } \Omega \quad (3.4a)$$

$$\frac{\partial \phi_c}{\partial n} = 0 \quad \text{on } \Gamma \quad (3.4b)$$

for cases

- $Q_y \neq 0$, $Q_z = 0$ and by defining $\phi_{cy}(y, z)$ as the resulting warping function
- $Q_y = 0$, $Q_z \neq 0$ and by defining $\phi_{cz}(y, z)$ as the resulting warping function

In the previous, we have consider a beam with constant (along the longitudinal axis of the beam) cross-section with an arbitrarily shaped occupying the two-dimensional simply or multiply connected region Ω of the y ; z plane bounded by the curve Γ . The aforementioned boundary value problem arises from the equation of equilibrium of the three-dimensional theory of elasticity neglecting the body forces and the physical consideration that the traction vector in the direction of the normal vector n vanishes on the free surface of the bar.

The numerical solution of the boundary value problem stated above (3.4a,b) for the evaluation of the (shear) warping functions ϕ_{cy} and ϕ_{cz} is accomplished employing a pure BEM approach [3.4], that uses only boundary discretization. Finally, since the torsionless bending problem (transverse shear loading problem) of beams is solved by the BEM, the



domain integrals in equations (3.3a,b) are converted to boundary line integrals in order to maintain the pure boundary character of the method [3.1-3.3]. Thus, once the aforementioned (shear) warping functions are established along the boundary, the shear deformation coefficients α_y , α_z are evaluated using only boundary integration.

BIBLIOGRAPHY

- [3.1]. Sapountzakis E.J. and Mokos V.G. (2005). “A BEM Solution to Transverse Shear Loading of Beams”, *Computational Mechanics*, 36, 384-397.
- [3.2]. Sapountzakis E.J. and Protonotariou V.M. (2008) “A Displacement Solution for Transverse Shear Loading of Beams Using the Boundary Element Method”, *Computers and Structures*, 86, 771-779.
- [3.3]. Sapountzakis E.J. and Mokos V.G. (2007) “3-D Beam Element of Composite Cross Section Including Warping and Shear Deformation Effects”, *Computers and Structures*, 85, 102-116.
- [3.4]. Katsikadelis, J.T (2002) *Boundary Elements: Theory and Application*, Elsevier, Amsterdam-London.



4. Applications with Scada Pro

Next, the cross-sectional properties of four cross-sections (with arbitrary shape) are calculated with Scada Pro by applying the Boundary Element Method (BEM), and compared with those obtained from a FEM solution using the Nastran software [4.1].

4.1 Cross-Section 1

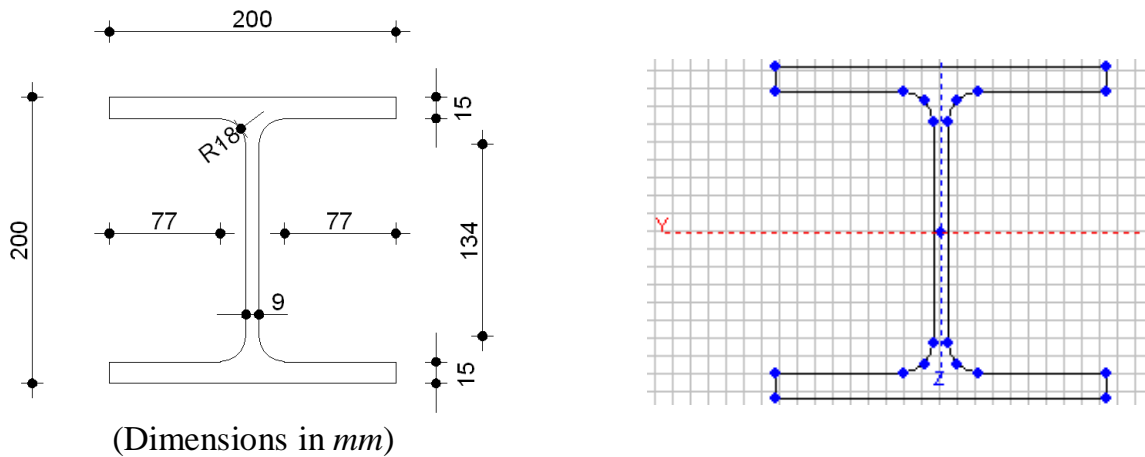

Img. 4.1. Cross-Section 1: Standard Steel Section HEB-200.

Table 4.1.a Cross-Sectional Properties of Cross-Section 1.

Variables	Scada Pro - BEM	NASTRAN - FEM [4.1]	Divergence (%)
A(m ²)	0.00782	0.00781	0.08
I _{yy} (dm ⁴)	0.57032	0.56994	0.07
I _{zz} (dm ⁴)	0.20035	0.20035	0.00
I _{xx} (dm ⁴)=I _t (dm ⁴)	0.00621	0.00605	2.60
A _{sy} (m ²)	0.00540	0.00554	2.39
A _{sz} (m ²)	0.00174	0.00174	0.06

Table 4.1.b Cross-Sectional Properties of Cross-Section 1.

Variables	Thin Tube Theory [4.2] (=Approximate theory for I _t , A _{sy} , A _{sz})	Divergence (%)
A(m ²)	0.00781	0.12
I _{yy} (dm ⁴)	0.57000	0.06
I _{zz} (dm ⁴)	0.20000	0.18
I _{xx} (dm ⁴)=I _t (dm ⁴)	0.00593	4.55
A _{sy} (m ²)	0.00600	11.02
A _{sz} (m ²)	0.00248	42.53



4.2 Cross-Section 2

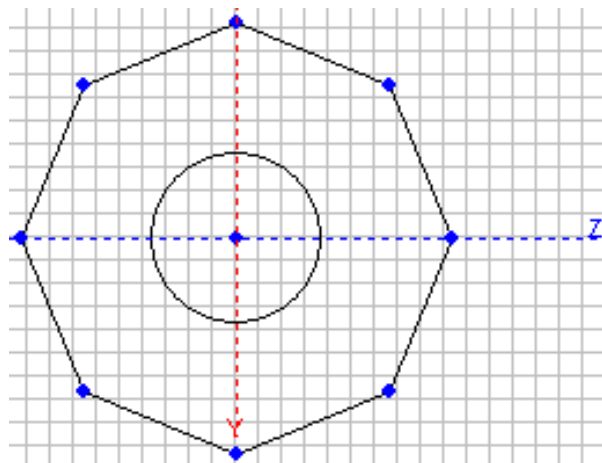
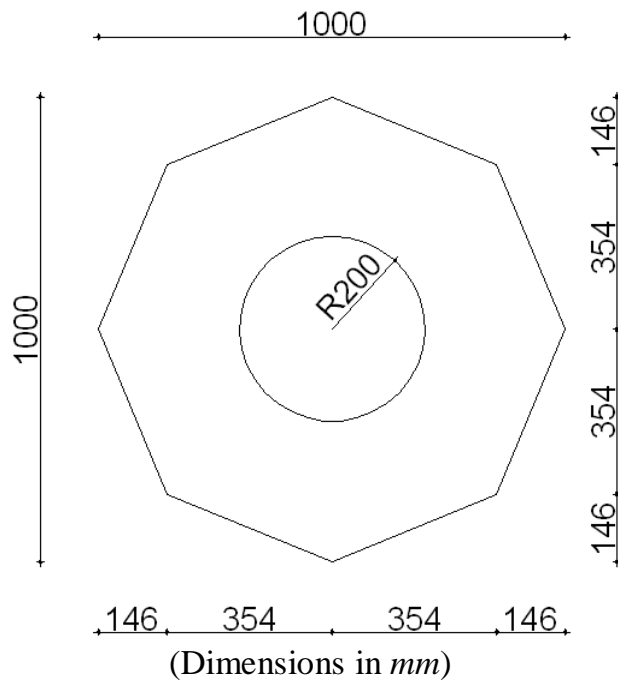

Img. 4.2. Cross-Section 2: Octagonal cross-section with circular hole.

Table 4.2. Cross-Sectional Properties of Cross-Section 2.

Variables	Scada Pro - BEM	NASTRAN - FEM [4.1]	Divergence (%)
$A(m^2)$	0.58169	0.58205	0.06
$I_{yy}(dm^4)$	386.27760	386.35000	0.02
$I_{zz}(dm^4)$	386.27714	386.35000	0.02
$I_{xx}(dm^4)=I_t(dm^4)$	758.09210	759.19000	0.14
$A_{sy}(m^2)$	0.36347	0.38305	5.11
$A_{sz}(m^2)$	0.36346	0.38303	5.11



4.3 Cross-Section 3

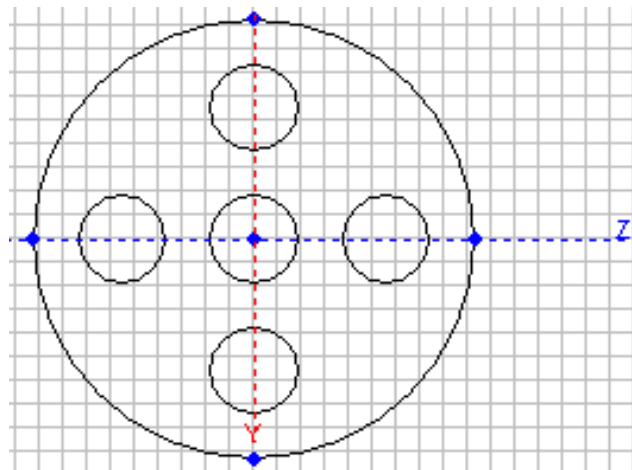
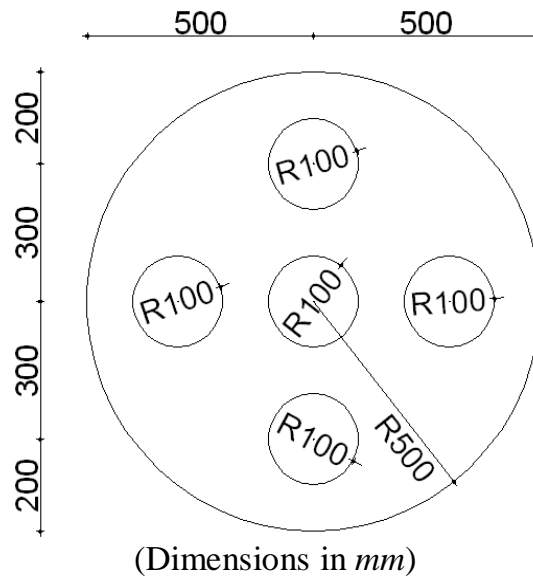

Img. 4.3. Cross-Section 3: Circular cross-section with circular holes.

Table 4.3. Cross-Sectional Properties of Cross-Section 3.

Variables	Scada Pro - BEM	NASTRAN - FEM [4.1]	Divergence (%)
$A(m^2)$	0.63066	0.63002	0.10
$I_{yy}(dm^4)$	430.91242	430.74000	0.04
$I_{zz}(dm^4)$	430.91014	430.74000	0.04
$I_{xx}(dm^4)=I_t(dm^4)$	769.91490	772.56000	0.34
$A_{sy}(m^2)$	0.41166	0.43080	4.44
$A_{sz}(m^2)$	0.41167	0.43077	4.43



4.4 Cross-Section 4

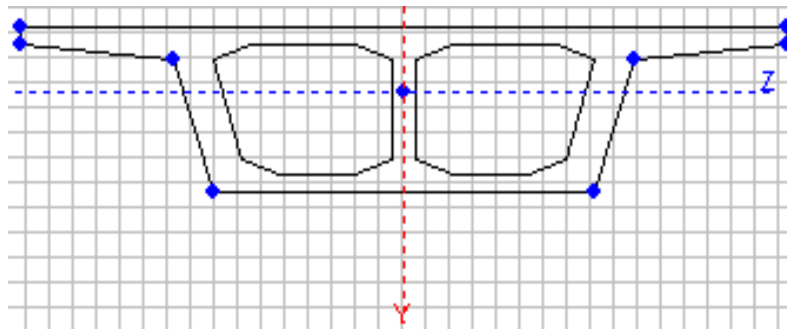
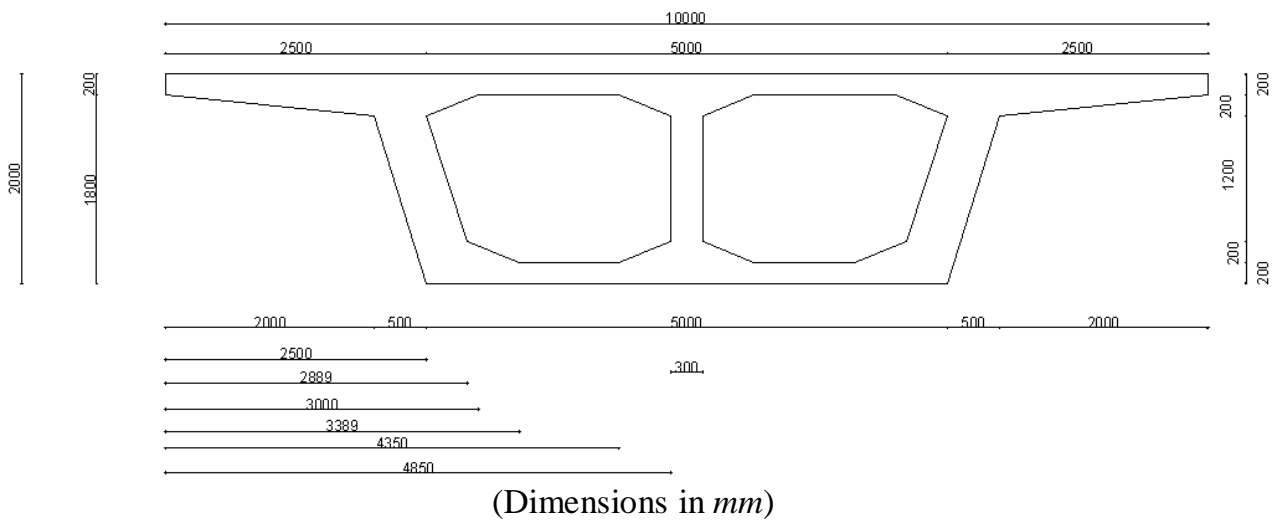

Img. 4.4. Cross-Section 4: Box shaped Cross-Section.

Table 4.4. Cross-Sectional Properties of Cross-Section 4.

Variables	Scada Pro - BEM	NASTRAN - FEM [4.1]	Divergence (%)
A(m ²)	5.90222	5.90222	0.00
Iyy(dm ⁴)	358398.38916	358399.00000	0.00
Izz(dm ⁴)	30854.50044	30854.50000	0.00
Ixx(dm ⁴)=It(dm ⁴)	69539.06692	69251.80000	0.41
Asy(m ²)	1.78525	1.74197	2.48
Asz(m ²)	3.40743	3.47200	1.86

From the above representative examples the reliability, the accuracy, the effectiveness, and the large range of applications for the Scada Pro Software in calculating the cross-sectional properties of 3-D beam element with an arbitrarily shaped cross section is established.

ΒΙΒΛΙΟΓΡΑΦΙΑ

[4.1]. MSC/NASTRAN, *Finite element modeling and postprocessing system*, USA.
 [4.2]. Schneider, K.J.: *Bautabellen für Ingenieure*, Werner Verlag GmbH & Co (13 Auflage), Düsseldorf, Germany, (1998).